

**Part Number: PT347-76111**

**NOTE:** Part number of this accessory may not be the same as the part number shown.

**Kit Contents**

Item #	Quantity Reqd.	Description
1	1	Spider Net

**Hardware Bag Contents**

Item #	Quantity Reqd.	Description
1	N/A	

**Additional Items Required For Installation**

Item #	Quantity Reqd.	Description
1	N/A	

**Conflicts**

None
------

**Recommended Tools**

<b>Personal &amp; Vehicle Protection</b>	<b>Notes</b>
None	
<b>Special Tools</b>	<b>Notes</b>
None	
<b>Installation Tools</b>	<b>Notes</b>
None	
<b>Special Chemicals</b>	<b>Notes</b>
None	

**General Applicability**

All 2011> 080A vehicles
-------------------------

**Recommended Sequence of Application**

Item #	Accessory
1	

\*Mandatory

**Vehicle Service Parts** (may be required for reassembly)

Item #	Quantity Reqd.	Description
1		
2		
3		

**Legend**



**STOP:** Damage to the vehicle may occur. Do not proceed until process has been complied with.



**OPERATOR SAFETY:** Use caution to avoid risk of injury.



**CAUTION:** A process that must be carefully observed in order to reduce the risk of damage to the accessory/vehicle and to ensure a quality installation.



**TOOLS & EQUIPMENT:** Used in Figures calls out the specific tools and equipment recommended for this process.



**REVISION MARK:** This mark highlights a change in installation with respect to previous issue.



**SAFETY TORQUE:** This mark indicates that torque is related to safety.

Care must be taken when installing this accessory to ensure damage does not occur to the vehicle. The installation of this accessory should follow approved guidelines to ensure a quality installation.

These guidelines can be found in the "Accessory Installation Practices" document.

This document covers such items as:-

- Vehicle Protection (use of covers and blankets, cleaning chemicals, etc.).
- Safety (eye protection, rechecking torque procedure, etc.).
- Vehicle Disassembly/Reassembly (panel removal, part storage, etc.).
- Electrical Component Disassembly/Reassembly (battery disconnection, connector removal, etc.).

Please see your Toyota dealer for a copy of this document.

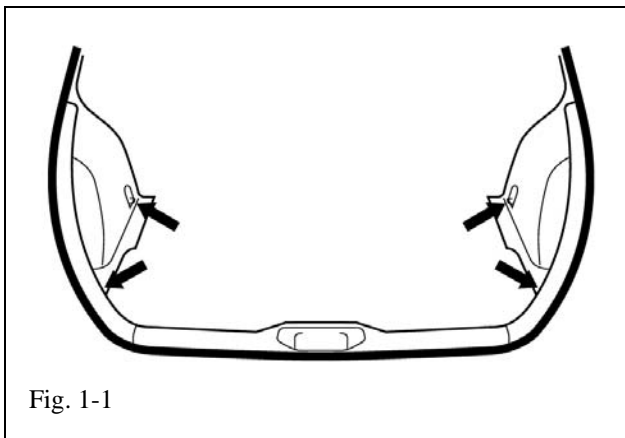

Fig. 1-1

### 1. Installation of Spider Net

(a) Locate the four anchor points in the vehicle as shown (Fig 1-1).

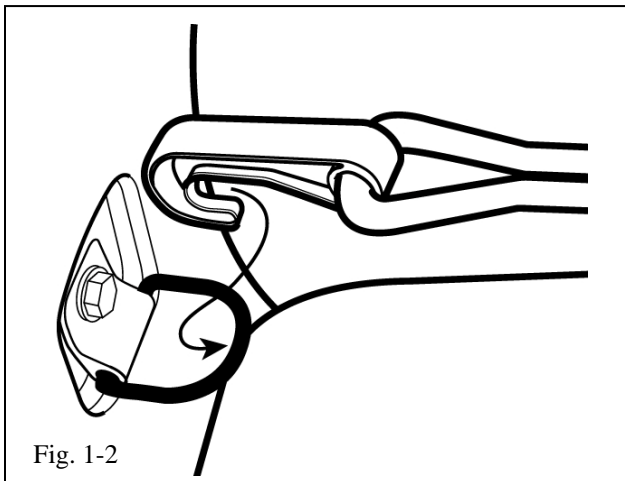
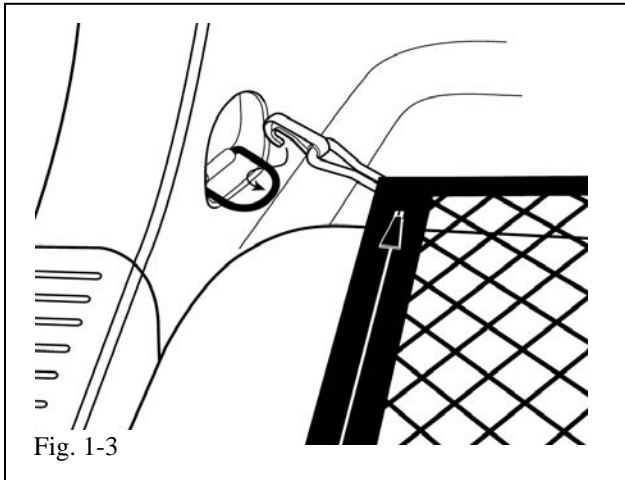
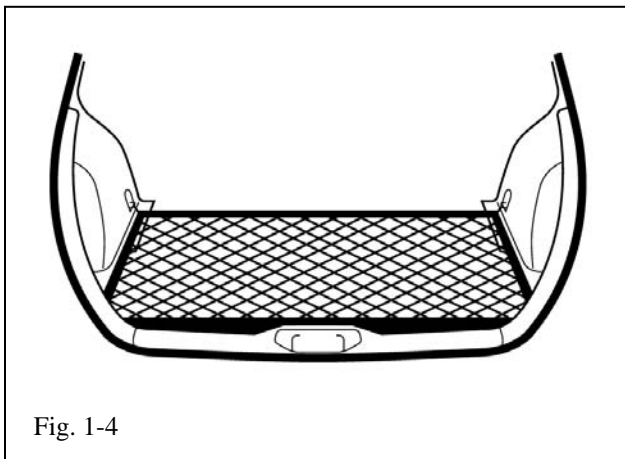



Fig. 1-2

(b) Lay out the net so the zipper is on top and at the rear of the vehicle. Starting on the driver's side of the vehicle, attach the hook at the front of the net to the D-ring as shown (Fig 1-2).



- (c) Attach the hook at the rear of the net to the D-ring as shown (Fig 1-3).
- (d) Attachment complete on the driver's side. Repeat step 1(a) through 1(c) for the passenger's side of the vehicle.



-  (e) Completed assembly. Make sure zipper is facing outward toward the rear of the vehicle (Fig 1-4).

Checklist - these points **MUST** be checked to ensure a quality installation.

Check:

Look For:

Accessory Function Checks

- Confirm the net is attached properly to the D-rings in the vehicle.

Ensure the net hooks are attached securely to all D-rings and not twisted.

Vehicle Function Checks

- Rear cargo door

Ensure the cargo door can open and close freely without interference from net.